

## FLEX-2

### FLEXIBLE EXTRACTION ARM

The Flex-2 is a wall-mounted flexible extraction arm with a rotatable hood *RotaHood*. Incorporated into the hood is a throttle valve that can be fully opened, partially opened or completely closed to control airflow at hood opening. The arm features a focus extraction spoiler, which directs the air into the hood.

The arm is provided with an *EasyLift* advanced friction system for light, user friendly positioning of the arm. The Flex-2 is suitable for stationary welding fume extraction systems only.



#### APPLICATIONS

The Flex-2 is intended to be used for the following applications:

- MIG-MAG/GMAW welding
- TIG welding
- FCAW welding
- stick/MMAW welding



Do **not** use the Flex-2 for the following Applications or in the following circumstances:

- arc-air gouging
- aluminium laser cutting
- extraction of aggressive fumes and gases (e.g. from acids, from alkaline, from soldering paste containing lithium)
- extraction of hot gases (more than 45°C/113°F continuously)
- grinding aluminum and magnesium
- flame spraying
- extraction of cement, saw dust, wood dust etc.
- sucking cigarettes, cigars, oiled tissues and other burning particles, objects and acids
- explosive environments or explosive substances/gases



#### SPECIFICATIONS

##### Physical dimensions and properties

Arm length	2 m (6.5 ft)
Diameter	203 mm (8 in.)
Material:	
• tube and hood	• polypropylene copolymere with UV stabilization
• hoses	• PVC with metal springs
• throat	• ABS
• handle, rim and grid	• nylon, glass fibre reinforced
Max. temperature (continuously):	
• tube and hood	• 80°C (176°F)
• hoses	• 80°C (176°F)
• throat	• 80°C (176°F)
• handle, rim and grid	• 95°C (203°F)
Colour:	
• tube and hood	• yellow RAL 1028
• hoses	• grey RAL 7024
Weight (net)	15 kg (33 lbs)

##### Performance

Airflow	max. 1600 m <sup>3</sup> /h (942 CFM)
<b>Ambient conditions</b>	
Operating temperature:	
• min.	• 5°C (41°F)
• nom.	• 20°C (68°F)
• max.	• 45°C (113°F)
Max. relative humidity	80%
Outdoor use allowed	no
Storage conditions	• 5-45°C (41-113°F) • relative humidity max. 80%
<b>Product combinations</b>	
TNB	wall bracket
TNB + FAN-14	wall bracket + fan
TNB + FAN-28	wall bracket + fan
<b>Available options</b>	
WL	working light
WL+AST	working light + automatic start/stop
<b>Scope of supply</b>	
Extraction arm - Hood - Rotating hinge (flange, collar, spring) - Hose 50 cm - Hose 165 cm - Bush (3) - Connection flange - Hardware	
<b>Order information</b>	
Article number	7925270090
Number/package	1
<b>Shipping data</b>	
Gross weight	20,5 kg (45 lbs)
Packing dimensions	160 x 30 x 45 cm (63 x 11.8 x 17.7 in.)
Max. number/pallet	6
Harmonized Tariff Code	8421.9900.99
Country of origin	the Netherlands

■ Approvals/certificates



Directive 2011/65/EC (RoHS)  
valid as of 8 June 2011

**FEATURES**

*EasyLift* balance system

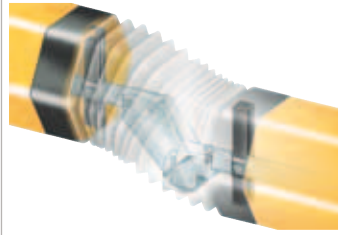

*RotaHood* 360° rotatable hood



**REACH**

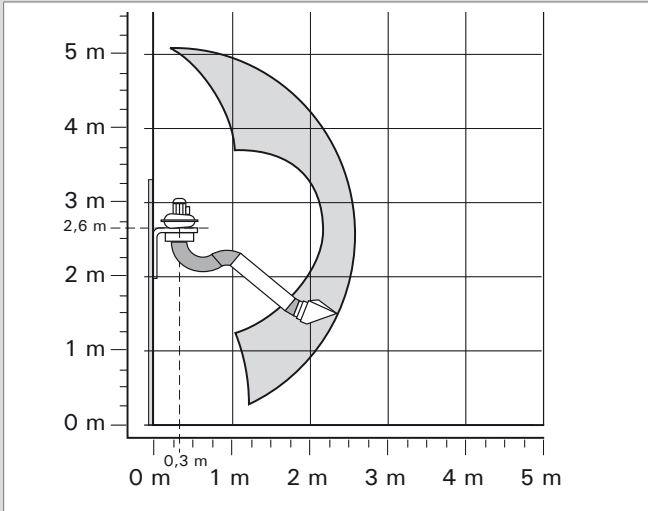

**PRESSURE DROP**

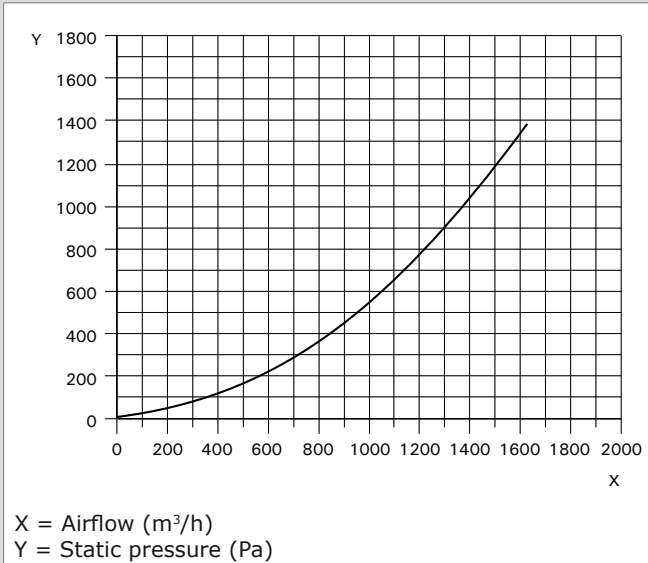

**MOUNTING MEASUREMENTS**

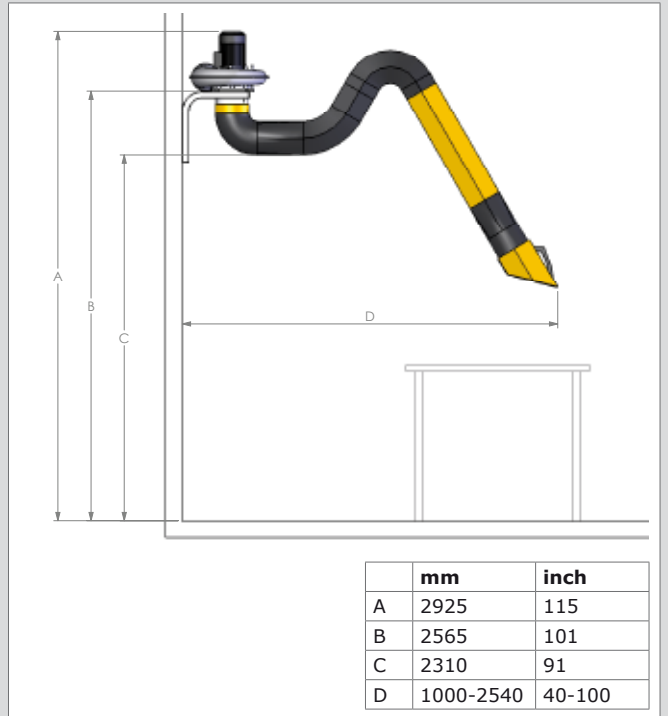

Flex-2 + TNB + FAN-14/28

Product type	<b>Flex-2</b>
Article no.	7925270090
Product category	extraction arms/hoses
Version	070212/D

Always check the latest version on [www.plymovent.com](http://www.plymovent.com)